

**NEW**



**Mini Crawler Crane**

# MC-305C-2

Lifting Capacity : **2.98t × 2.5m**

Maximum Working Radius : **12.16m × 0.26t**

Dimensions (L × W × H) : 4285 × 1280 × 1695mm

Outrigger Safety System

4Fall/2Fall Hook Block

Two Way Remote Controller



Moment Limiter Display



with electric motor spec



# MAEDA Mini Crawler Crane MC-305C-2

## Specifications

Model	MC-305CRMS(E)-2	
Crane capacity	t × m	2.98t × 2.5m
Max. working radius	m × t	12.16m × 0.26t
Max. lifting height (on the ground)	m	12.52m
Max. lifting height (underground)	m	-16.09m
Winch system	Hook speed	m/min 13.5m/min (4 layers 4 falls)
	Holst wire rope	φ × m IWRC 6 × WS(26) φ8 × 73m
Telescoping system	Type	Fully automatic 5-section pentagonal telescopic boom
	Boom length	m 3.695 ~ 12.485m
	Boom telescoping stroke / time	m/sec 8.79m/26sec
Boom hoist system	Hoist angle / time	deg/sec 0 ~ 80deg/14.5sec
Swing system	swing angle / time	deg/rpm 360deg/2.4rpm
Outrigger system	Type	Extended Hydraulic cylinder direct acting Setting up Hydraulic cylinder direct acting
	Max. extended width	mm (Lateral) 4,888 × (Front) 4,504 × (Rear) 4,396
Travel system	Type	Hydraulic motor driven, stepless speed changer
	Travel speed	km/h 0 ~ 2.8
	Gradability	deg 23
	Crawler ground length × width	mm 1750 × 300
	Ground pressure	kpa [kgf/cm <sup>2</sup> ] 36.3 [0.37]
Engine	Model	YANMAR 3TNV76
	Displacement	L [cc] 1,115 [1,115]
	Rated output	kw/min <sup>-1</sup> [ps/rpm] 15.2kw/2500min <sup>-1</sup> [20.7PS/2500rpm]
	Starting method	Electric starting
	Fuel / Fuel tank capacity	L Diesel/40.0
Motor (MC-305CRMSE-2)	Motor type	Totally enclosed fan-cooled motor 5.5kw, 4P 200V or 380V
	Starting system	Inverter system (30Hz-60Hz)
Remote control system	Type	Cable remote controller
	Micro/High speed mode	Available
	Load display for transmitter	Available
	Outrigger operation	Available
	Voice	Available
Overall length × width × height	mm 4,285 × 1,280 × 1,695	
Machine weight	kg 3,900kg (4,040kg with electric motor)	
Safety device	Overwind protection, Load indicator, Hydraulic safety valve, Wire rope latch, Level, Machine body inclination alarm, EMC switch, Travel lock lever, Outrigger interlock device, Moment limiter, Rotary lamp	
Options	White rubber track, Single fall hook, Searcher hook	

## Total Rated Load Chart (4 falls)

Total Rated Load Chart with outrigger extended to maximum							
5.945m Boom		8.145m Boom		10.315m Boom		12.485m Boom	
Working radius (m)	Total rated load (kg)	Working radius (m)	Total rated load (kg)	Working radius (m)	Total rated load (kg)	Working radius (m)	Total rated load (kg)
2.5 or less	2980	2.7	2270	4.0	1080	4.5 or less	790
3.0	2390	3.0	2120	4.5	985	5.0	660
3.5	1990	3.5	1880	5.0	880	6.0	520
4.0	1710	4.0	1440	6.0	770	7.0	430
4.5	1490	4.5	1260	7.0	670	8.0	380
5.0	1340	5.0	1110	8.0	570	9.0	340
5.62	1160	5.5	990	9.0	500	10.0	310
		6.0	880	9.99	435	11.0	280
		7.0	730			12.16	260
		7.82	630				

\* The Total Rated Load Chart is based on actual working radius with the bending of boom attributable to load reflected and is shown with the mass of hook (30kg) included.

## Working Range (4 falls)

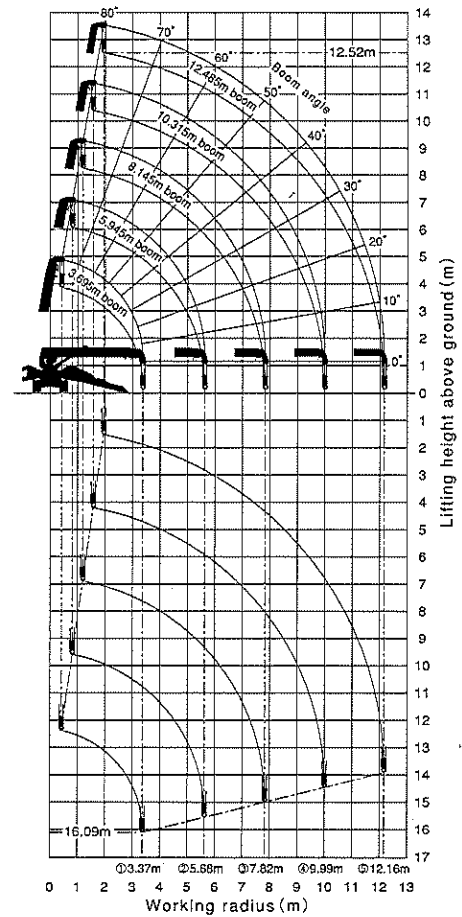

## Dimensions

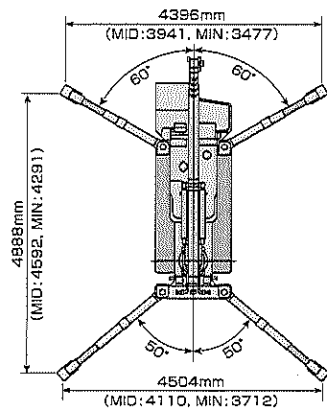
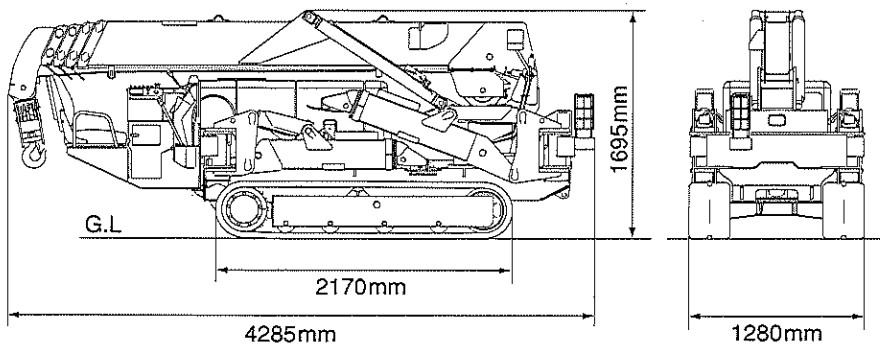

**! Before use, please read the Operation Manual**

Due to improvements, the specifications are subject to change without notice.



**MAEDA SEISAKUSHO CO., LTD.**

No.1095, Onbegawa, Shinonoi, Nagano-City, Nagano-Pref. 388-8522 Japan  
 Head office TEL: 026-292-2228 FAX: 026-293-5590  
 URL: <http://www.maesei.co.jp/> E-mail: [maedasp@maesei.co.jp](mailto:maedasp@maesei.co.jp)