

Specifications

MODEL Z-51/30J RT

MEASUREMENTS	Metric	Imperial
Working height max.*	17.4 m	57 ft 3 in
Platform height max.	15.6 m	51 ft 3 in
Horizontal reach max.	9.24 m	30 ft 4 in
Up and over clearance	7.16 m	23 ft 6 in
A Platform length	76 cm	2 ft 6 in
B Platform width	1.83 m	6 ft
C Height stowed	2.16 m	7 ft 1 in
D Length stowed	7.46 m	24 ft 6 in
E Width	2.2 m	7 ft 6 in
F Wheelbase	2 m	6 ft 8 in
G Ground clearance – centre	39.3 cm	15.5 in

PRODUCTIVITY

Lift capacity	227 kg	500 lbs
Platform rotation	160°	160°
Turntable rotation	355° non-continuous	355° non-continuous
Turntable tailswing	zero	zero
Drive speed – stowed	8 km/h	5 mph
Drive speed – raised**	0.965 km/h	0.6 mph
Lift speed to full height	52 sec.	52 sec.
Gradeability*** - 4x4	45%	45%
Turning radius – inside	1.6 m	5 ft 6 in
Turning radius – outside	4.5 m	14 ft 9 in
Controls	12 V DC proportional	
Tyres	355/55 D625 foam filled	

POWER

Engine	Deutz Diesel F3L 2011 3-cyl 48 hp (35.8 kW)	
Auxiliary power unit	12 V DC	
Tank capacities		
Hydraulic tank capacity	90.85L	24 gal.
Fuel tank capacity	64.35 L	17 gal.

WEIGHT

Weight****	7,240 kg	15,963 lbs
------------	----------	------------

STANDARDS COMPLIANCE

	CE EN280 Tier II emission compliant engine AS 1418.10
--	---

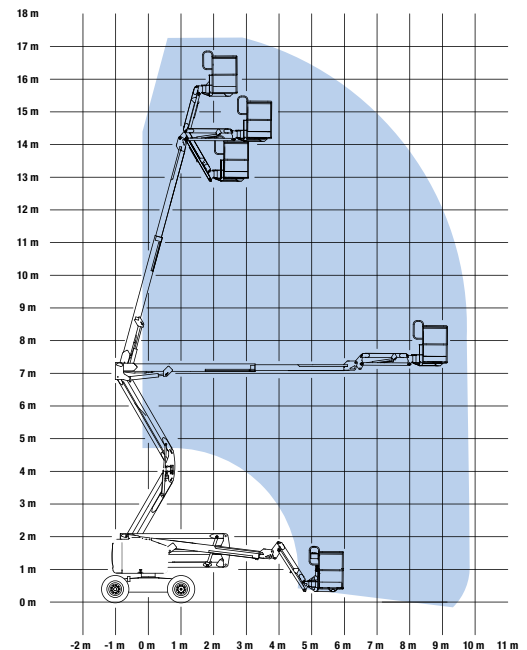
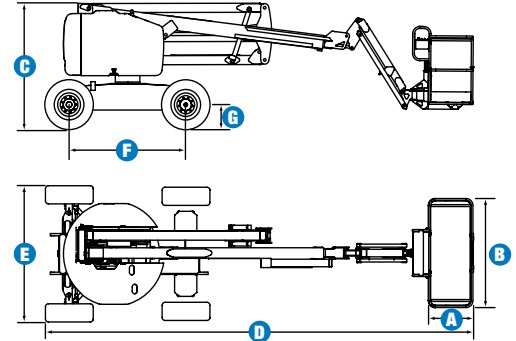

* The metric equivalent of working height adds 2 m to platform height. Imperial adds 6 ft to platform height.

** In lift mode (platform raised), the machine is designed to operate on firm, level surfaces only.

*** Gradeability applies to driving on slopes. See operator's manual for details regarding slope ratings.

**** Weight will vary depending on options and/or country standards.

Features

STANDARD FEATURES

MEASUREMENTS

- 17.6 m (57 ft 3 in) working height
- 9.2 m (30 ft 4 in) horizontal reach
- 1.52 m (5 ft) jib boom
- 227 kg (500 lb) lift capacity
- 1.8 m (6 ft) self-levelling steel platform

PRODUCTIVITY

- Hydraulic platform rotation
- Thumb rocker steer
- Positive traction 4 WD
- Active oscillating axle
- Rough terrain foam filled tyres
- Fully proportional controls
- 12 V DC auxiliary power unit
- Drive enable system
- Engine protection package
- AC power to platform
- Intake heater
- Horn
- Hour meter
- Tilt alarm
- Alarm package with beacon

POWER

- Deutz Diesel F3L 2011
3-cyl 48 hp (35.8 kW)



OPTIONS & ACCESSORIES

- Air line to platform
- Tool tray
- Platform work lights
- Front driving lights
- Lockable control box cover
- 5000 watt AC generator (240V 50Hz)
- Hostile environment package
- Arctic oil
- Arctic hoses
- Fluorescent tube caddy
- Diesel spark arrestor muffler
- Diesel exhaust spark arrestor/scrubber muffler
- Platform swing gate
- Half mesh platform

Genie Australia

591 Boundary Road, Darra, Qld 4076
PO Box 394, Richlands, Qld 4077
Tel: + 61 7 3375 1660
Toll Free In Australia: 1800 331 660
Fax: + 61 7 3375 1002

European Offices

UK

The Maltings
Wharf Road
Grantham NG31 6BH
UK
Tel: +44 (0)1476 584333
Fax: +44 (0)1476 584334

France

10, ZA de la Croix St. Mathieu
28320 Gallardon
France
Tel: +33 (0)2 37 26 09 99
Fax: +33 (0)2 37 26 09 98

Germany

Finienweg 3
28832 Achim/Bremen
Germany
Tel: +49 (0)4202 8852-0
Fax: +49 (0)4202 8852-25

Spain

Gai`a 31, Pol. Ind. Pl`a d'en Coll
08110 Montcada i Reixac
Barcelona
Spain
Tel: +34 93 572 50 90
Fax: +34 93 572 50 91

Scandinavia

Tagenevägen 72
425 37 Hisings Kärra
Sweden
Tel: +46 31 57 51 00
Fax: +46 31 57 90 20

Genie United States

18340 NE 76th Street
P.O. Box 97030
Redmond, Washington 98073-9730
USA
Tel: +1 425 881-1800
Fax: +1 425 883-3475

WEB: www.genieindustries.com

Distributed By: